

Optimum Material Properties for Improved Bearing Performance

Materion Brush Performance Alloys' ToughMet® family of copper-nickel-tin alloys is tailor-made for bearing applications. ToughMet possesses a unique combination of mechanical and physical properties that improve bearing performance. Its good hardness minimizes wear, while its exceptionally high resilience reduces the potential for spalling and pitting of the bearing surface. Its spinodally-hardened microstructure provides low friction, which works in concert with the material's good thermal conductivity to minimize the temperature rise in the bearing. This in turn helps to prevent seizing, scuffing, and scoring of the bearing surface.

HERTZIAN STRESS

Hertzian stress refers to the stress induced at the interface between two bodies held in contact by an external force. For a bushing/sleeve bearing application, one cylinder (the shaft) rests inside another cylinder (the bushing/bearing). In strict mathematical terms, the contact between two tangent nested cylinders is a line. However, dividing the bearing load by an infinitely thin contact area results in an infinite pressure along the line of contact! This is clearly not the case, so the two surfaces must be deforming along the points of contact so that the load is distributed over a small, but finite, area.

In the case of the bushing or sleeve bearing subjected to a load (W), the contact area would be rectangular. It will have a length (L) equal to the length of the bushing/bearing, and a width given by the formula below¹:

$$B = \sqrt{\frac{2 \cdot W}{\pi \cdot L} \cdot \frac{(1 - \nu_1^2)/E_1 + (1 - \nu_2^2)/E_2}{1/D_1 - 1/D_2}}$$

Here, B is half the width of the contact area, as shown in Figure 1. (The radial clearance is exaggerated for clarity.) Most of the terms in the equation are determined by the geometry of the system. However, both Poisson's ratio (ν) and the elastic modulus (E) of the bushing and shaft material come into play. Poisson's ratio is around 0.3 for most metals, so this term is typically unaffected by material

choice. However, the elastic modulus of the two materials can be significantly different. A material with a high elastic modulus would be stiff, and thus the resulting contact area would be relatively small. A material with a lower elastic modulus would be more flexible, and the resulting contact area would be greater.

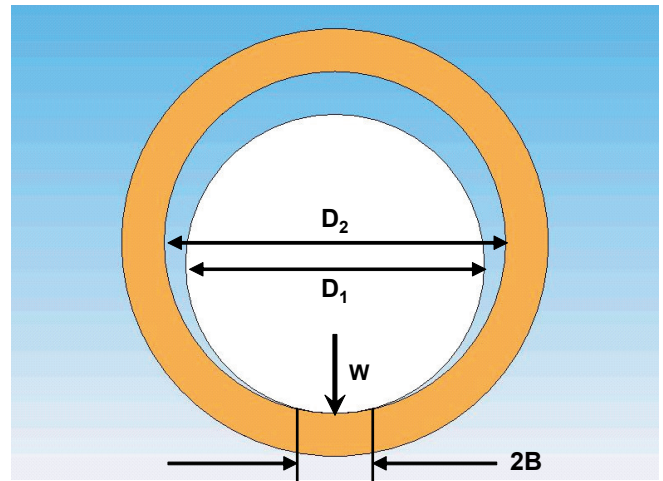

Figure 1 – Contact Width (2B)

The average pressure in the contact zone would simply be the bearing load (W) divided by the contact area (L X 2B). However, the actual pressure is unevenly distributed, being greatest along the contact zone centerline and falling to zero at the edge of the contact area. The maximum pressure is defined as follows¹

$$P_{MAX} = \frac{2 \cdot W}{\pi \cdot B \cdot L}$$

The interface pressure and the associated deformation of the contact surfaces induce stresses in the metal in the contact zone. If the stress becomes too high, the bearing/bushing can permanently deform under the load placed on it by the shaft. The bearing material thus needs to have a high compressive yield strength to withstand this load without yielding.

Without getting into the detailed mathematics involved, the maximum shear stress generated is approximately 30% of the maximum pressure, and is located inside the metal at a distance away from the surface of approximately 75% of the contact half-width¹. These shear stresses can result in sub-surface fatigue crack propagation, which can result in spalling of the surface of the bearing.

The ideal bearing material will thus need to have a high yield strength (and fatigue strength) and a low elastic modulus, in order to both minimize and withstand the stresses associated with the bearing load. The ratio of yield strength to elastic modulus is encountered often in mechanical problems, and has been given the name **elastic resilience**.

BEARING TEMPERATURE RISE

The following equation from the Cast Bronze Bearing Design Guide² estimates the temperature rise of a bearing:

$$\Delta T = \frac{0.02 \cdot \mu \cdot W \cdot D_1 \cdot N}{hf \left[0.011(D_2^2 - D_1^2) + 0.02D_2L + \left(\frac{0.065kD_1^2C}{L^*} \right) \right]}$$

Here, μ is the average coefficient of friction, N is the shaft RPM, h is the convective heat transfer coefficient between the bearing and the ambient atmosphere, k is the combined thermal conductivity of the shaft and bearing, L* is the distance from the center of the bearing to the free end of the shaft, and f and C are factors which tend to vary from 0.7 to 0.9 and 0.1 to 0.2, respectively.

The numerator of the above equation describes the bearing

power lost through conversion to heat. The temperature rise can be reduced by minimizing the coefficient of friction and by maximizing the thermal conductivity of the bearing, as these are the only two material properties in the above equation.

FLASH TEMPERATURE

Unless the bearing is in full hydrodynamic mode, there will be some metal-to-metal contact between the asperities (high spots) on the mating surfaces. These asperities bear the majority of the load as they slide past each other. Frictional heating due to the extremely high pressure in the contacting asperities results in a dramatic temperature rise, known as a flash temperature. Although this temperature is fleeting, it can be sufficient to melt and weld the asperities together. The welded asperities will then be torn apart as the shaft continues to rotate in the bearing. This is known as adhesive wear.

Over time, the microscopic welding tends to increase to a macroscopic level, resulting in noticeable metal removal and transfer, known as scuffing. The loose debris may also cause scoring of the shaft and/or bearing. Resistance to these modes of degradation can be obtained by minimizing the flash temperature. This can be accomplished by reducing the bearing load (often not possible), decreasing the surface velocity, and increasing the bearing length (risking additional wear problems due to misalignment). These are all geometric changes that will significantly change the bearing characteristics.

The flash temperature can also be reduced by the use of full hydrodynamic lubrication (which is difficult to obtain and maintain in heavily loaded systems). Alternatively, a material with a low and consistent coefficient of sliding friction would have reduced frictional heating and more resistance to welding. A more resilient material will provide a larger contact width (B), which will spread the bearing load and reduce the pressure and flash temperature at the asperities. A material with increased thermal conductivity, density, and specific heat will also help the material absorb and disperse heat before it has a chance to melt and weld.

ToughMet 3 possesses an excellent combination of low friction, high resilience, good conductivity, and wear resistance. It will tolerate high bearing stresses, and still show low power loss and low heat generation, extending bearing life, (as shown in Figures 2 and 3).

Materion Brush Performance Alloys

6070 Parkland Boulevard
Mayfield Heights, OH 44114 USA
phone: 216.486.4200 fax: 216.383.4005
e: BrushAlloys-Info@Materion.com

TECHNICAL INQUIRIES

ph: 800.375.4205

MATERION CORPORATION

www.materion.com

AT0055/0311

©2011 Materion Brush Inc.

Toughmet Cuts Friction in Half

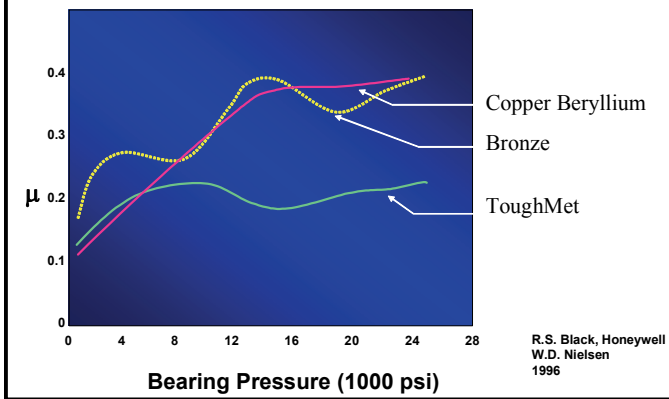

Figure 2 – Friction Behavior

References:

- 1) Shigley, J.E. and Mischke, C.R. Mechanical Engineering Design McGraw-Hill, Inc. 1989. pp 71-74
- 2) Cast Bronze Bearing Design Manual Copper Development Association/Cast Bronze Bearing Institute Inc. 1959 pp A-1 to A-3

ToughMet® is a registered trademark of Materion Brush Inc.

ToughMet Resists Wear the Best

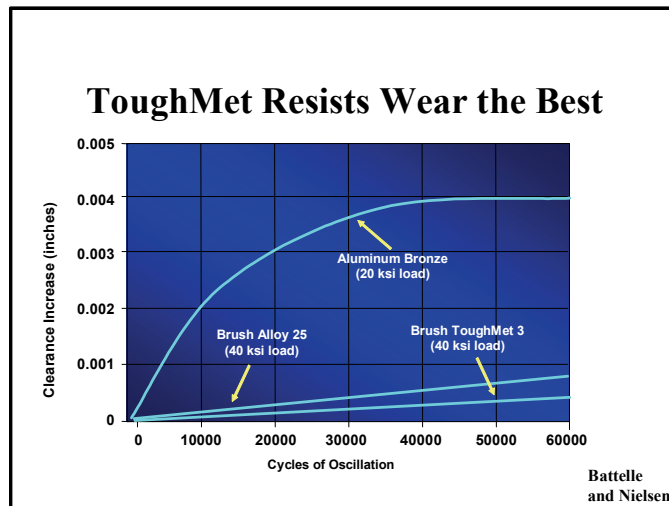

Figure 3 – Wear Behavior

Materion Brush Performance Alloys

6070 Parkland Boulevard
Mayfield Heights, OH 44114 USA
phone: 216.486.4200 fax: 216.383.4005
e: BrushAlloys-Info@Materion.com

TECHNICAL INQUIRIES

ph: 800.375.4205

MATERION CORPORATION

www.materion.com

AT0055/0311

©2011 Materion Brush Inc.